

ELECTRONIC STETHOSCOPE FOR EHEALTH AND TELEMEDICINE

Christian McMechan¹, Poman So¹, Kin Fun Li¹, Gordon Jasechko², and Martin Poulin²

¹*University of Victoria, Victoria, BC, Canada*

²*Vancouver Island Health Authority, Victoria, BC, Canada*

INTRODUCTION

The success of ehealth and telemedicine depends on the development of advanced medical equipment that can streamline the tasks of medical data collection, processing and archiving. Audio signals such as respiratory sounds, heart sounds and abdominal sounds, detected by stethoscopes are some of the basic signals used by physicians for audible auscultation but there is no standard procedure to process, transmit, and archive the collected data digitally. This may be due to the fact that the electronic stethoscopes are still expensive when compared to mechanical stethoscopes. The slow adoption of electronic stethoscopes by medical practitioners indicates they are reluctant to rely on these devices.

Electronic stethoscopes have many advantages over the mechanical ones. The electronic ones enable physicians to collect, archive, and process acoustic medical signals easily. Moreover, it is possible to include medical diagnostic features in electronic stethoscopes as suggested in [1]. Furthermore, feature-laden devices may even be used by non-medical specialists to collect data remotely for physicians. Also, “user friendly” electronic stethoscopes that general public may easily use to transmit their own heart and lung audio signals to their family physicians via the telephone or Internet would be good tools for telemedicine as proposed in [2]. Therefore, adoption of electronic stethoscopes by the medical community would be a win-win scenario for all parties involved which include patients, physicians, and the medical instrumentation industry.

We are investigating the desirable features and requirements for an affordable electronic stethoscope. There are diverse focuses in research on electronic stethoscopes. Johnson’s group implemented an ultra-low power electronic stethoscope [3], but without additional enhancements and features. Luo proposed a Bluetooth-based stethoscope with real-time display, recording, and playback features [4]. An electronic stethoscope with embedded DSP (Digital Signal

Processing) capability has been developed to illustrate the feasibility of diagnosing heart murmur remotely [5]. The most ambitious project yet was the multifunction stethoscope proposed by Wang et al. [6] which was supposed to include automatic diagnosis features for telemedicine; however there is no evidence that the proposed stethoscope has been successfully implemented. In fact, advanced digital signal processing and diagnostic features such as those described in [3 – 6] are not needed in all models and could be made available as add-on components.

Our primary goal is to bring the unit price down so that electronic stethoscopes could become common household items very much like the electronic body temperature thermometers. With the help of instruction pamphlets, parents could use electronic stethoscopes to monitor the general health of their family members. Medical data collected by electronic stethoscopes may be used by nurses and physicians in telemedicine, and in normal clinical settings.

MARKET SURVEY

Electronic stethoscopes can amplify weak sound signals electronically and store the signal in digital formats for further processing. Currently, there are several major players in the marketplace, including 3M Littmann [7], ADC [8], Thinklabs [9], Cardionics [10], and AMD [11]. All models provide some form of filtering at various frequency ranges, amplifying low-level sound, and reducing ambient noise. They also differ in the type of battery used: AA, AAA, and Lithium Ion. Infrared transmission and Bluetooth are the common communications modes employed. High-end electronic stethoscopes often feature playback, volume control, Liquid Crystal Display (LCD), auto shut-off, heart rate reading and sound analysis software. There is a wide variability in pricing, from a basic model of \$200 to a high-end one at \$3,000. However, none of the above models provide a Universal Serial Bus (USB) interface to external storage devices.

ESSENTIAL AND OPTIONAL FEATURES

Compared to the mechanical stethoscopes which cost from \$10 to \$100 [12–15], electronic stethoscopes are much more expensive. The cost of electronic stethoscopes could be reduced if only limited features are included in the entry models. One of these features is a circuit for providing good sound quality for audible auscultation. Electronic stethoscopes do not have to rely on the rubber tubing to transmit sound energy from the chest-piece to the ear-piece. Connecting the two pieces together electrically can eliminate loss of sound energy and reduction of signal quality due to the tubing. Electronics for switching the frequency response of the chest-piece to cardiac (low frequency murmurs) and pulmonary (higher frequency) examination are essential. Ambient noise rejection and volume amplification are also desirable. The above features as well as microprocessor for processing sound signals can be integrated in the circuitry embedded in the chest-piece. This area has sufficient room to include a micro Secure Digital (SD) card module and possibly optional electronic interfaces. The features to be included in the proposed stethoscope may be divided into the following categories.

Hardwired to the Stethoscope

Anything hardwired to the stethoscope should be unnoticeable and transparent to the users. Therefore add-on sensors that convert audio signals to electrical signals must be very light and small, and embedded in the chest-piece. This is well achieved by most commercially available electronic stethoscopes. Sound signals can be transmitted by a detachable wire or wirelessly to a computer in real time. Alternatively, sound signals from the sensors could be recorded automatically without the intervention by the physician, and stored in a micro SD card placed within the chest piece. The wireless or SD-card design allows the stethoscope to be used like a normal mechanical stethoscope. For the stored signals to be useful, patients' identification must be recorded with the sound signals. This can be achieved easily by just "talking softly" to the chest-piece before using it on the patients. A USB interface may be used for charging and data transfer.

Wirelessly Connected the Stethoscope

Wireless connection between the stethoscope and a computer is desirable for real time processing and analysis of the collected signals. Wireless technologies are evolving rapidly hence the main challenge in this area is to avoid unwanted interference by other

electronic medical equipment. If the use of cell-phones is not allowed in certain hospital areas, the use of wireless stethoscope accessories having the same frequency band as cell-phones would have to be examined carefully. Since the stethoscope has a long rubber tube, it is very easy to embed a long antenna in the tubing to transmit data at a lower frequency. Other wireless transmission options include Wireless Local Area Network (WLAN or Wi-Fi) and Personal Area Network (PAN or Bluetooth) technologies. In addition to electronic interference, another criterion to be considered is low-power consumption.

Features for Ehealth and Telemedicine

Digital archiving, signal processing, and medical diagnostic features can be implemented in separated software modules on a device that is not connected directly to the electronic stethoscope. Whether the data is stored in the memory of the stethoscope, on the hard disk of a personal computer, or off-site on a data server, patient privacy and data security are important issues that must be addressed. To support ehealth and telemedicine applications, an Internet based data server is the best way to provide centralized data archiving service. In this scenario, information privacy and data security issues are compounded many folds. Furthermore, data must be encrypted at all times; only medical practitioners with special software may make use of the stored data.

Since heart sounds can be used to diagnose heart problems [6], it would be useful to collect the heart sound of a patient for a long duration of time. Hence a wearable stethoscope with multiple sticky chest-pieces could be a very useful diagnostic tool for heart diseases. Audio data collected by such an enhanced electronic stethoscope would be the counterpart of the ECG signal collected by a Holter monitor [16].

A LOW-COST PROTOTYPE DESIGN

A low-cost electronic stethoscope prototype is being designed. As show in Figure 1, the prototype consists of several building blocks that can be individually modified and upgraded. In order to be ergonomically functional, the transmission link between the chest-piece and the display should ideally be wireless, using either cellular, Wi-Fi or Bluetooth technology, as shown in Figure 2. The device is to be battery powered with a low voltage to avoid accidental electrical shock to the patient and to maximize the operating time on a single charge.

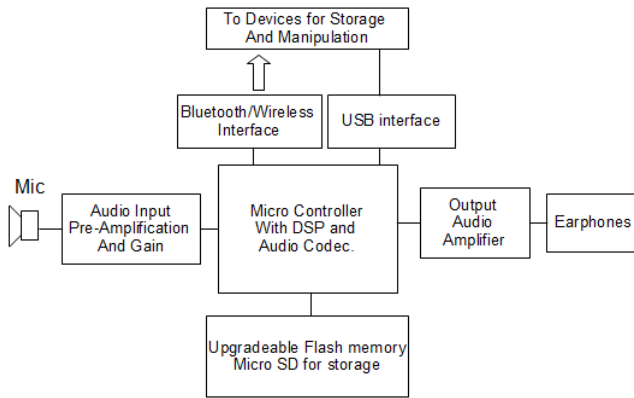

Figure 1: Block Diagram of an Electronic Stethoscope Prototype

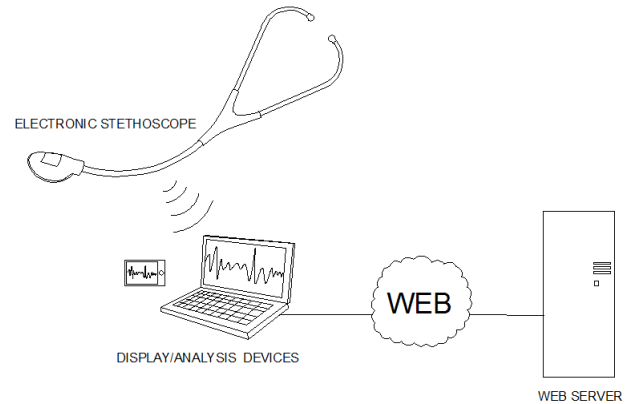

Figure 2: Diagram of an Operational Electronic Stethoscope System

Chest-Piece

Various sound acquisition methods are being investigated including using a miniature electret condenser microphone or a piezoelectric contact microphone, both with pre-amplifying and filtering capability. As seen in other models, the chest piece is large enough to house the audio input electronics, an LCD, buttons, battery and main printed circuit board (PCB). In order to make the electronic stethoscope more ergonomic for the medical professional, a start/stop recording, volume and power buttons would likely be located here. More investigation into the final design form factor is to be performed.

On the main circuit board would be an embedded system that may contain application-specific circuitry and a microprocessor with specific on-chip digital signal processing hardware. Its main function is to filter out the undesired frequency ranges, amplify the resulting signal, remove undesirable ambient noise, and convert the analog signals into digital data. These tasks ideally are to be done in real time using dynamic digital filtering techniques. Processed data (recordings that can be switched on and off) are temporarily stored in the unit using a SD card, and transferred to the computer or display device using established wireless file transfer protocols, or a USB wired interface. The files could then be transferred and filed in a web database for future reference or comparison. The exact wireless technology to be used is under investigation. Devices like the Blackberry™, iPod™, Bluetooth headsets, etc. use Lithium polymer batteries to achieve a more than acceptable run and standby times. The stethoscope should be powered by a rechargeable internal battery to save space and weight, as well as maximize the battery performance of the unit.

Ear-Piece

An appropriate audio listening system is to be designed and must be compatible with the sound recording device used in the chest-piece. It will comprise of a high quality ear bud style pair of headphones mounted in a way so as to fit the traditional form factor. The ear piece would be directly connected to a small amplifier which amplifies the analog converted signal out from the microcontroller /microprocessor.

Power and Charging

The power consumption and running life would be another major factor in the success of a low cost and practical stethoscope. The stethoscope would have to be as power efficient as possible to meet a medical practitioner's needs such that a charge is not required for hours if not an entire work day. This, of course, would have the stethoscope under normal to heavy use. Battery technology has fairly recently made some major advancement that enables extremely light weight batteries to provide power for hours to demanding devices. As stated on the chest-piece section, an internal rechargeable battery would be the best option in order to keep the unit light weight and compact.

Display

Any display that can show the wave form of the detected signals can be used as a visual aid in the medical diagnostic process. Depending on the specific setting, this display could be a personal computer, a small but powerful hand held device such as an iPod™, or a sophisticated table-top signal monitoring device. The display should be able to display real-time

or stored time-sequence signals. If a software suite were to be developed and used with the electronic stethoscope, then further analysis of the gathered data may be later performed on the display device. The software could contain algorithms to more accurately identify possible discrepancies and anomalies in the measured signal in order to aid the practitioner in an accurate diagnosis.

Web Database

A Web database system is needed to archive the collected data. Internet technology provides an ideal setting for storing time-sequence data that can be accessed anywhere, anytime. Through a well-designed Web interface, medical personnel can retrieve and examine the collected data, and possibly diagnose the health condition of a patient. Information privacy and computer security are added dimensions to be considered in this module.

CONCLUSION

The design of the electronic stethoscope prototype is in progress, starting with the most important modules such as the chest-piece and the main processing module. With cost being our primary design criterion, the parts required are being reviewed extensively and selected carefully to reflect the feasibility of a low cost, yet feature flexible, electronic stethoscope. A proof-of-concept working stethoscope was realized in March 2010. Further design refinement and development will continue incrementally throughout 2010. A working prototype ready for field test is expected by the end of 2010.

ACKNOWLEDGEMENTS

The authors wish to acknowledge the contribution of Eric Chan, Jonathan Cheng, Timothy Kwan, Benjamin Lee, and Joseph Kylo, all are students in the Department of Electrical and Computer Engineering at the University of Victoria, who bravely assuming the task of completing a proof-of-concept low-cost electronic stethoscope as their final-year engineering design project.

REFERENCES

- [1] W.W. Myint and B. Dillard, "An electronic stethoscope with diagnosis capability", Proceedings of the 33rd Southeastern Symposium on System Theory, pp. 133 – 137, 2001.
- [2] K. Luk, B.L. Choy, W.H. Tai, B. Tso, and S.K. Hung, "Multifunction stethoscope for telemedicine", IEEE International Workshop on Computer Architectures for Machine, pp.87 – 89, 2003.
- [3] J. Johnson, et al., "An ultra-low power subband-based electronic stethoscope", Proceedings. 2006 IEEE International Conference on Acoustics, Speech and Signal, Volume: 3, pp. 1516 – 1519, 2006.
- [4] Y. Luo, "Portable Bluetooth visual electrical stethoscope research", 11th IEEE International Conference on Communication Technology, 634 – 636, 2008.
- [5] Y.-W. Bai, C.-H. Yeh, "Design and implementation of a remote embedded DSP stethoscope with a method for judging heart murmur", IEEE Instrumentation and Measurement Technology Conference, pp. 1580 – 1585, 2009.
- [6] H. Wang, J. Chen, Y. Hu, Z. Jiang, S. Choi, "Heart sound measurement and analysis system with digital stethoscope", 2nd International Conference on Biomedical Engineering and Informatics, pp. 1 – 5, 2009.
- [7] http://solutions.3m.com/wps/portal/3M/en_WW/global-littmann/home/ 3M-Littmann, March 15, 2010.
- [8] <http://www.adctoday.com/ecatalog/stethoscopes.php> ADC, March 15, 2010.
- [9] <http://www.thinklabsmedical.com/> Thinklabs, March 15, 2010.
- [10] <http://www.egeneralmedical.com/caelst.html> Cardionics, March 15, 2010.
- [11] <http://www.amdtelemedicine.com/telemedicine-equipment/cardiology/amd-3550-smartsteth-digital-electronic-stethoscope.html> AMD, March 15, 2010.
- [12] <http://www.allheart.com/electronic-stethoscopes.html> All Heart, March 15, 2010.
- [13] <http://www.quickmedical.com/professional/stethoscopes/electronic.html> Quick Medical, March 15, 2010.
- [14] <http://www.grxmedical.com/grxmedicalstethoscopes.aspx> GRX Medical, March 15, 2010.
- [15] <http://www.professionaluniform.com/> ("Stethoscopes and Blood Pressure Cuffs" on the left panel), March 15, 2010.
- [16] http://en.wikipedia.org/wiki/Holter_monitor Holter Monitor, March 15, 2010.