

## 3D RAPID PROTOTYPING FOR SYNCHROTRON APPLICATION

Christopher H. Ryan<sup>1</sup>, Tomasz W. Wysokinski<sup>2</sup>, L. Dean Chapman<sup>3</sup>, Malgorzata Korbas<sup>4</sup>

<sup>1</sup>*Physics and Engineering Physics, College of Engineering, University of Saskatchewan, Saskatoon, SK, S7N 5A9, CANADA*

<sup>2</sup>*Biomedical Imaging and Therapy Beamlines, Canadian Light Source, Saskatoon, SK, S7N 0X4, CANADA*

<sup>3</sup>*Anatomy and Cell Biology, College of Medicine, University of Saskatchewan, Saskatoon, SK, S7N 5E5, CANADA*

<sup>4</sup>*Molecular and Environmental Science Group, Department of Geological Science, University of Saskatchewan, Saskatoon, SK, S7N 5E2, CANADA*

### ABSTRACT

The Biomedical Imaging and Therapy (BMIT) Beamlines at the Canadian Light Source (CLS) is designed for the purpose of imaging and radiation therapy research both with animals ranging from mice to horses and humans. Being the only beamline in the world with this capacity, BMIT will be continuously encountering unique problems requiring innovative solutions. 3D rapid prototyping has proven to be one of the possible solutions.

There are a variety of applications for 3D rapid prototyping (RP) in the Synchrotron environment. At BMIT, rapid prototyping will be the primary concentration for fabrication of unique and difficultly machined precision instruments and animal restraints.

The designing and manufacturing process of such unique components includes:

1. Development of 3D model of part which could include an x-ray CT or MRI scan of animal.
2. Conversion of model or scanned data to CAD formats.
3. Fabrication of unique component using 3D printer.

Conventional prototyping techniques are expensive, time consuming and dated. With late advancements in 3D printing, scanning, and CAD software, the task of 3D-RP is becoming more readily available, cost effective, accurate and provides quick turnaround. This paper describes the current and future technologies of each process, which will be implemented at the BMIT beamlines to ensure maximum resolution image quality, while improving efficiency and reducing stress on the animals.

### INTRODUCTION

Rapid prototyping technique is used to improve images and to provide tools necessary for radiation therapy research. Much of the instruments used on the Biomedical Beamline will require micron ( $\mu\text{m}$ ) level precision, which is typically difficult to obtain in a prompt manner and at a sensible cost. Conversely, developing a 3D CAD model and utilizing the 3D printer provides a fabrication accuracy of up to 16  $\mu\text{m}$  and fabrication in a minimal amount of time and cost effective manner. Experiments on the Hard X-ray Micro-Analysis (HXMA) beamline at the CLS, have employed RP devices in order to improve the image quality of live animal subjects. One of the experiments include Gene Expression Mapping using synchrotron light (GEMS), where 3D-RP was used to create a Soller slit assembly to collimate the x-rays, as well as create an animal restraint mechanism. The BMIT project has also used 3D-RP to assist in the conceptual design of animal and human positioning systems.

### MODEL DEVELOPMENT

The Model Design procedure may be simply based on a 3D CAD design which is readily output in a format which is accepted by the rapid prototyper. Traditional methods require 2D drafting and fabrication by machine shops. 3D CAD software is steadily replacing conventional 2D drafting, accelerating the design cycle. However, the 3D information may be in the form of a medical CT or MRI. In this case it is necessary to convert the image format into one acceptable by the prototyper. An increasing number of software packages are making this task easier.

Developing a CAD design from an existing component/animal requires additional effort and various file conversion steps so that it can be

manipulated using the CAD software. Medical scanning systems such as CT/MRT are required and they produce the image in DICOM format. This DICOM file is converted into an STL file and becomes readable by CAD software. This conversion process is lengthy and complicated. Members of our research group are presently exploring a number of options for this conversion. Specifically ones in which allow the editing of the objects imported from the medical imaging system [1]. In the future, technology may provide us with more convenient and economical methods such as time-of-flight laser triangulation.

The CAD software used in these experiments was SolidWorks® 2007. 3D CAD software facilitates the design and production process.

### FILE FORMATS

Once the model is created using appropriate software, the model can be converted to a number of formats compatible with a 3D printer. Those formats include SolidWorks® files (SPRT), Standard Tessellation Language (STL) and Standard for the Exchange of Product model data file (STEP).

### 3D PRINTING

Next step is to produce the components using a printer. 3D printer produces high quality, accurate, and cost effective prototypes in a very short time. This technology can produce prototypes with a resolution of 16 µm (0.016 mm). The University of Saskatchewan Engineering Shops operates the EDEN500V 3D printer that is using PolyJet™ Technology. This innovative technology operates by continually injecting thin layers of photopolymer material onto the build tray until the model is complete. UV light cures each layer of the photopolymer material. This process is outlined in figure 1. The prototype is produced with a gel-like material surrounding it, in order to support the design. This gel material is removed using a high-pressure water system. The prototype is then ready for operation.

Short-term exposure to radiation does not immediately affect this photopolymer material and it is advantageous for use in experiments such as GEMS because there are no high-Z elements in the polymer which would create unnecessary x-ray attenuation or fluorescence. Durability to high x-ray exposure has not been determined, though none is expected for the present or perceived applications.

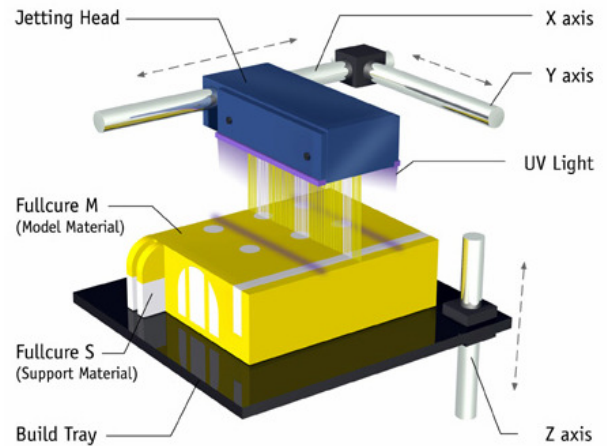

Figure 1. Object PolyJet Process (Courtesy of University of Saskatchewan Engineering shops)

### APPLICATIONS

#### GEMS Experiment

Green fluorescent protein (GFP) gene is currently being used as the primary reporter of mapping expression [2]. GEMS is currently researching the possibility of using an iodine accumulator to replace the GFP marker. Iodine in sufficient concentrations is easily detected by either an edge subtraction method or fluorescence imaging method. This allows for gene expression monitoring deep within the animals' body and the ability to target single cells. Fluorescence detection permits the detection of extended x-ray absorption fine structure (EXAFS) [3]. Using this technique, genetically engineered cancer tumors were placed in rats' brains. A sodium iodide solution was injected into the rat to allow for the fluorescence imaging and K-edge subtraction imaging of tissues which have accumulated iodine.

Soller slits were required on the multi element (32) germanium (Ge) energy dispersion detector to axially collimate the incident beam, see figure 2, and to reduce the signal to noise ratio by decreasing the fluorescence background from the antimony filters.

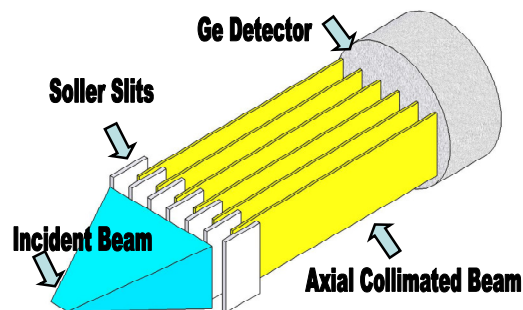

Figure 2. Soller Slits Function

The slits provide a definite horizontal divergence angle of  $6.33^\circ$  and contain a set of closely spaced horizontal metal plates lined with lead tape, designed to reduce the vertical divergence as much as possible. The soller slits were an important, yet late addition to the experiment and therefore required rapid production and micron level precision, which proved to be a perfect candidate for the 3D-RP techniques. From design to complete manufacturing of the soller slits took two days. This experiment was the first time that a fluorescence image was created by subtracting fluorescence images acquired just above and below the K-absorption edge of an element. This process significantly improved sensitivity of iodine. Due to the success in reducing the signal to noise ratio, the Soller slits was extended to accommodate focusing in the vertical direction as well.

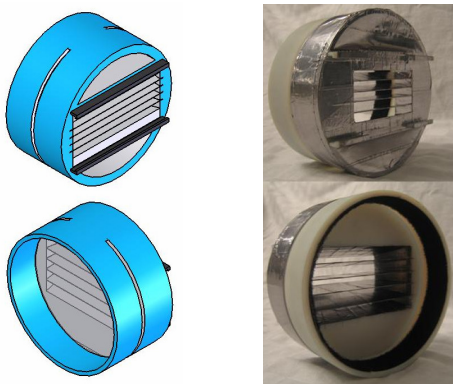

Figure 3. Soller Slit; CAD Design and Manufactured

A fluorescence image was obtained using these soller slits. It was made using four different Ge detector elements. Two images were taken using each element, one below the K-edge and one above. The two images of each element were then subtracted from each other. The resulting images were added together to form figure 4.

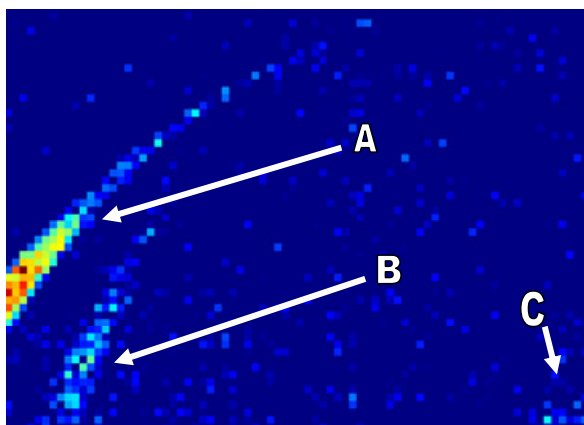

Figure 4. Fluorescence Difference Image

- A) micropipette of concentration 50 mM NaI,
- B) micropipette of concentration 10 mM NaI,
- C) fluorescence scattering.

This image shows ends of micropipettes filled with sodium iodine (NaI) solution of various concentrations tightly closed and implanted into the rat brain. The micropipettes were used as a test object to check which NaI concentration could still be seen in live animals. Images were taken using a pencil beam  $0.25 \times 0.25 \text{ mm}^2$  in size. The region scanned was  $20 \times 18 \text{ mm}^2$ . Previous images taken without the Soller slits were completely saturated with scatter and reveal no distinguishable objects. With use of the slits this image clearly shows two tips. (Note: at such high energy levels Compton scattering dominates over elastic scattering, therefore even with soller-type slits and antimony (Sb) filters, some scattering will occur (area C in figure 4).

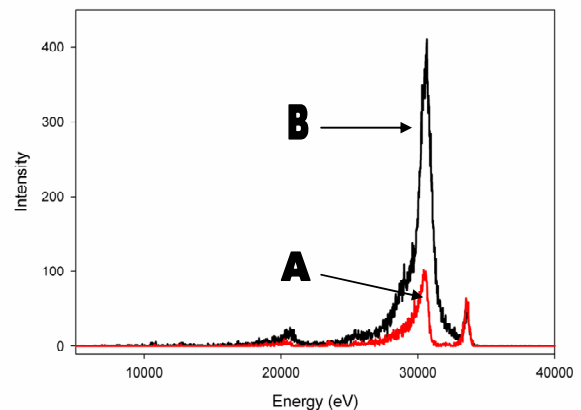

Figure 5. Fluorescence Spectra with (A) and without (B) Soller slits.

Figure 5 shows comparison of two spectra collected at 33.25 keV: one with (A) and one without (B) soller slits. It illustrates improvement of the data resulting from the reduction of scattering when using the slits.

The GEMS experiments also required an animal restraint mechanism needed to reduce the movement of a rat while being imaged. Restraining animals is difficult, therefore the animal may be anaesthetized. While their movement is limited, their breathing continues and reverberates throughout the body. This movement reduces the image's resolution. The movement can be minimized if the restraint system is a perfect fit for the animal. 3D RP was used to develop and fabricate a shell that conforms to the shape of the animals head based on data obtained from a medical CT scan [1].

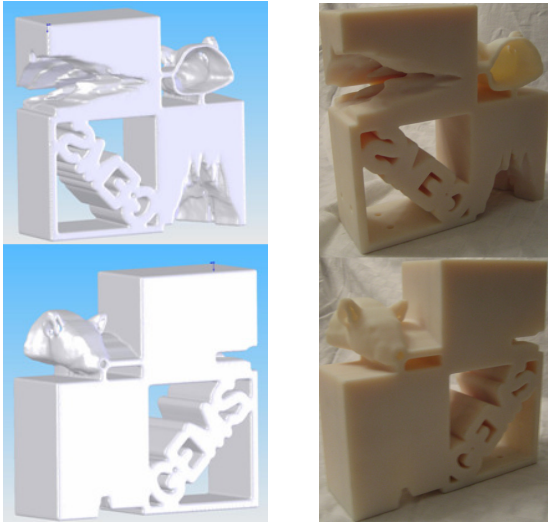

Figure 6. Animal Restraint; CAD Design and Manufactured

#### BMIT Positioning System Model

A positioning system for animals and later humans will be needed to conduct proper CT/MRT scans using the synchrotron light. The positioning system was based on a 3 circle, 30° Kappa Goniometry design, with horizontal translation and vertical scanning capabilities. One of the design stages focused on developing a 1:16 scale model to test the design and confirm that the movement stages would meet the preliminary design requirements. The scale model with five degrees of freedom motion was printed without the need to assemble. It was used to review various design options, which then could be optimized prior to fabrication of the real size machine.

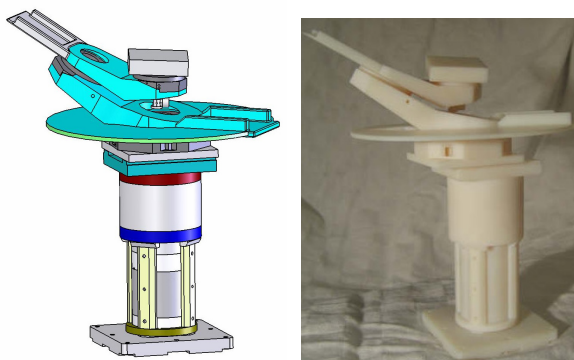

Figure 7. Positioning System; CAD Design and Manufactured

#### **CONCLUSION**

A number of applications of rapid prototyping to synchrotron radiation research and development have

been given. The ability to "print" arbitrary structures has enabled us to develop animal restraints that closely fit live animals and thus reduce motion artifacts. This is especially important for imaging methods that require temporal stability of the subject. Additionally, the ability to create this restraint with a thin polymer shell reduces x-ray signal loss due to absorption for both projection imaging and fluorescence imaging. The success of the rat restraint allows for the possibility of using similar techniques to restrain smaller animals or even larger animals. Animals as small as mice and as large as horses are envisioned on the BMIT beamline.

The RP capability has also allowed us to manufacture complex slit mechanisms which has improved our signal gathering ability while increasing the noise or scattered x-ray rejection. The speed and affordability of the RP allows researchers to react quickly to changing needs. This is especially important in synchrotron radiation research where beamtime is limited both in duration and frequency.

Finally, we have demonstrated the use of the RP for modeling complex systems that will be implemented on the BMIT beamline, specifically, the positioning system. This system with its multiple degrees of freedom are hard to visualize and appreciate without a solid 3D model.

#### **ACKNOWLEDGEMENTS**

This work is supported by the College of Physics and Engineering Physics University of Saskatchewan, Canadian Light Source Experimental Facilities Division, Canada Research Chairs program, Saskatchewan Health Research Foundation Research Group Grant, Natural Sciences and Engineering Research Council, The Canadian Institutes of Health Research (#68849 to Prof. G. N. George, University of Saskatchewan) (MK). BMIT is supported by the Canada Foundation for Innovation Infrastructure Grant.

#### **REFERENCES**

- [1] Y. Zhu, *et al.*, "The use of rapid prototyping for small animal restraint in synchrotron biomedical imaging," *accepted to Nuclear Instruments and Methods in Physics Research*, 2007
- [2] G. J. Phillips, "Green fluorescent protein – a bright idea for the study of bacterial protein localization," *FEMS Microbiology Letters*, vol. 204, pp. 9-18, 2001.
- [3] E. A. Stern and s. M. Heald, "X-ray filter assembly for fluorescence measurements of x-ray absorption fine structure," *Review of Scientific Instruments*, vol. 50, pp. 1579-1582, 1979