

TELECOACHING IN TRAUMATOLOGY

R. Lemieux¹, P. Masson³, C. Bellemarre¹, M. Martin^{1,2}, D. Bisson¹, M.-È. Bernard³, P. Fauteux³, C. Julien³, M. Lalonde-Filion³, C. Morier³, A. Morin-Guimond³, M.-A. Patry³, A. Saint-Pierre³, P. Moisan⁴, F. Michaud⁴

¹Centre hospitalier universitaire de Sherbrooke, ²Dept. Traumatology, ³Dept. Mechanical Engineering, ⁴Dept. Elec. Eng. & Comp. Eng., Université de Sherbrooke, Sherbrooke (Québec) CANADA J1K 2R1

INTRODUCTION

The Canadian public health care system is facing a shortage of emergency specialists, including trauma surgeons [1]. General practitioners (GPs) are more than ever called to provide medical care in emergency rooms in order to keep the service to the population at an adequate level. This is particularly true in remote regions of Canada. GPs working in emergency rooms are faced with life-and-death situations where performing surgical procedures on trauma patients is the only way to save their life. By lack of continued training opportunity, they use techniques that are not best suited to obtain optimal results.

Telecoaching systems in traumatology aim at providing assistance to local physician in performing surgery procedures using proper kinesiological gestual on unstable polytraumatized patients. Tele-assistance by an expert is a concept that was widely used in other fields of medicine before emergency medicine. Examples are radiology [2], pathology [3] and psychiatry [4]. Real-time tele-consultation with an emergency specialist offers significant benefits to patients in regions where no specialists are available and patients are frequently transferred to specialized centres [5,6]. Significant reduction in medical assistance costs and in response time of professionals also resulted from tele-consultation in emergency medicine [6]. The practice of tele-emergency through videoconferencing is currently available for minor injuries [6]. Tachakra *et al.* [7] showed concordance above 95% in comparing tele-medicine with face-to-face consultations for trauma management of minor injuries, both in terms of diagnostic precision and quality of medical assistance. In the case of major injuries, preliminary studies indicate significant benefits of tele-medicine in both patient life support surveillance [8] and patient management [9].

Emergency medicine specialty is a relatively new program. In this context, the *Centre Hospitalier Universitaire de Sherbrooke* (CHUS) has developed a program of tele-training in trauma medicine where trauma surgeons use kinesiology movement

decomposition to teach emergency physicians the proper techniques to perform eight frequently used surgical procedures on polytraumatized patients (endotracheal intubations, comb tube installation, cricothyroidotomy, needle tracheotomy, thoracotomy, pericardiosynthesis, central venous approaches, and sapheno-femoral dissection). After several training sessions, the CHUS team concluded that real-time coaching of emergency physicians in performing surgical procedures on trauma patients would be the best way to 1) assist emergency physicians with difficult cases, 2) help them gain manual dexterity and 3) maintain their level of expertise up-to-date. In the context of a shortage of trauma surgeons, the development of a tele-coaching system could provide help on demand and consequently, could improve the level of services in trauma medicine given to the population of regions where trauma surgeons are unavailable.

Therefore, technologies to provide telementoring services constitute a very promising avenue to address these challenges. At the same time, design issues of telementoring systems are broad and mostly unexplored, with very few systems currently available. Rogers *et al.* [10] studied the benefits of tele-coaching in 26 trauma medicine cases. The system used was composed of two cameras. The first one was ceiling mounted above the trauma stretcher and controllable at distance by the remote trauma surgeon. The second camera was fixed on a table and allowed global viewing of the trauma room. They showed significant benefits to patients in terms of morbidity and mortality (two lives saved). They concluded that the mobile ceiling mounted camera was best suited for such application, although the system showed limitations.

To go further with this idea, the CHUS, the Faculty of Medicine and Health Sciences and the Faculty of Engineering of the Université de Sherbrooke teamed up and developed two original proof-of-concept prototypes using a pair of robotized semi-teleoperated cameras located above the trauma stretcher. This paper summarizes the functionalities of these prototypes and the investigation currently underway with them.

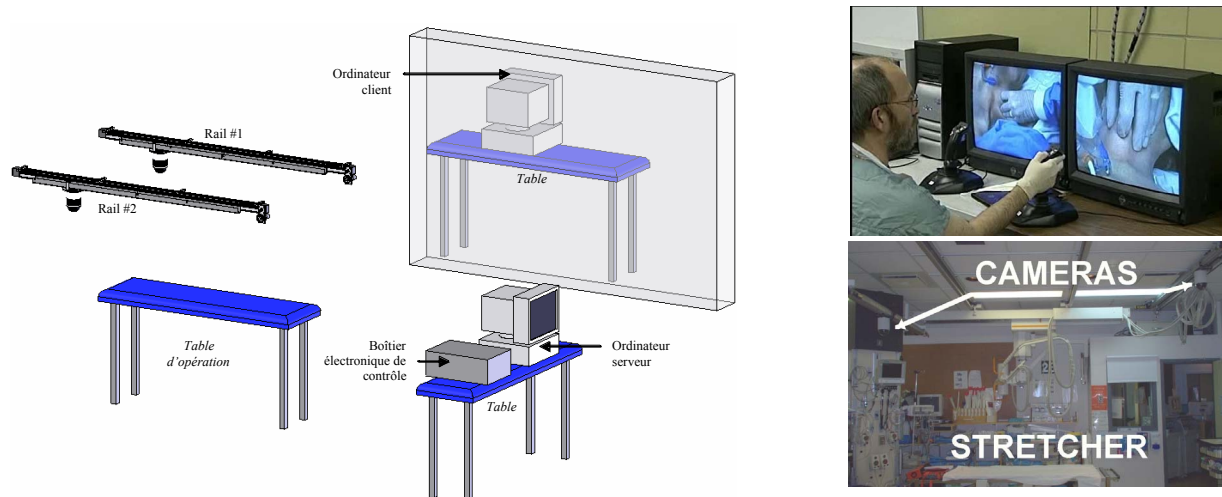

Fig. 1 – Prototype 1 schematics (left), remote control (top right) and installation (bottom right)



a) Thoracic drain



b) Cricothyroidotomy



c) Venous access

Fig. 2 Camera views during interventions performed by a non-physician

PROTOTYPE 1 – TWO SIDE RAILS

This prototype, shown in Fig. 1, is composed of two independently controllable cameras, ceiling-mounted on rails on the sides, above the trauma stretcher. Each camera is capable of the following movements: pan, tilt, rotation, zoom and longitudinal movement at variable speed along its rail. Either one of the cameras is used to provide a global view while the other is focusing on the surgical intervention. Real-time communication (video and audio) exists between the remote trauma surgeon and the on-site emergency physician. Camera movements are controlled independently using joysticks, a graphical user interface and TCP/IP transmission protocol, which simplifies coding and transmission of video images using CODECs (Tanberg T3000). To help the remote expert concentrate on the surgical procedure, pre-determined positions are available through the interface to minimize camera positioning. Fig. 2 shows images as seen by the remote surgeon teleoperating the cameras. These trials were done at the CHUS using an intranet.



Fig. 3 Inappropriate field of views provided by the cameras

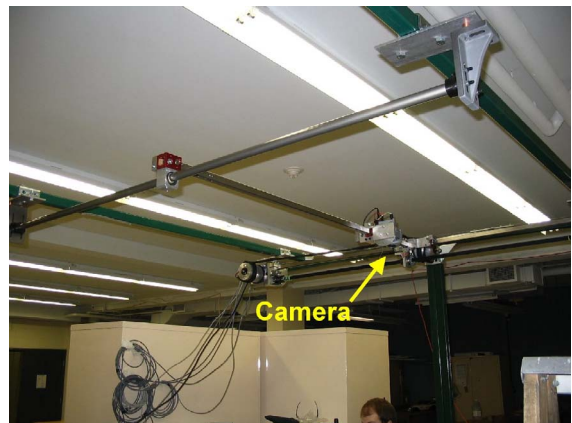
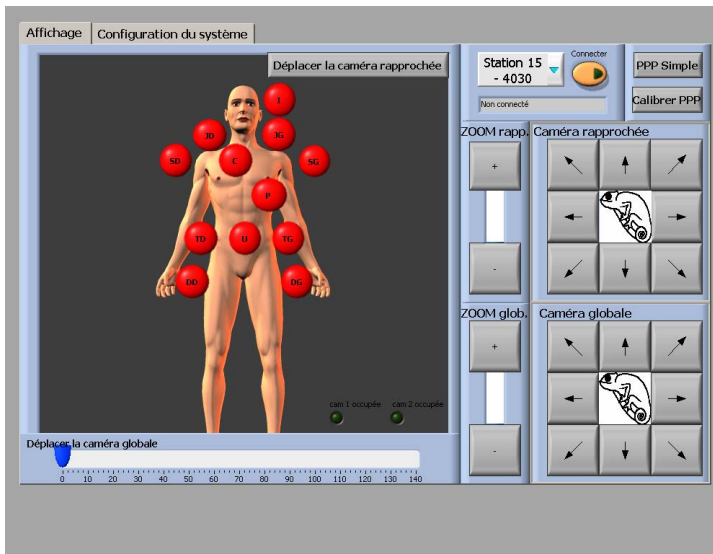
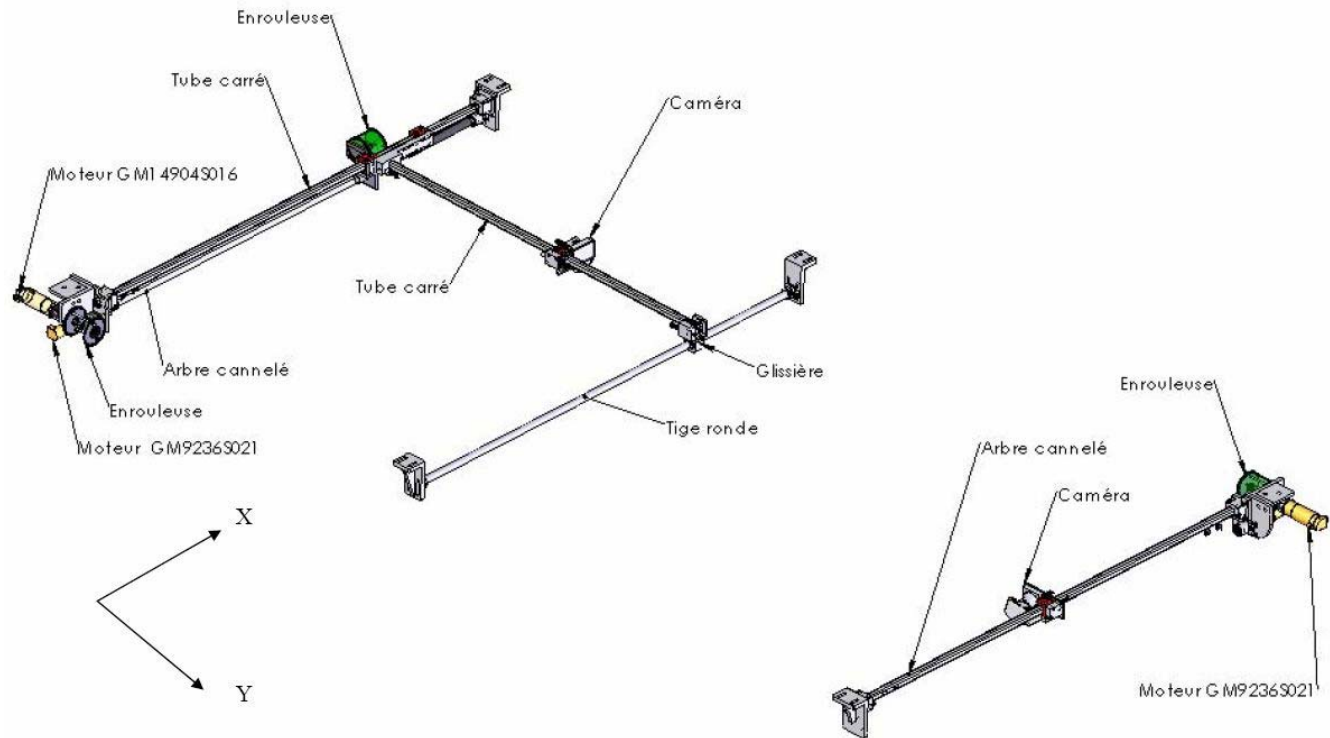

Fig. 4 – Prototype 2 schematics (top), user interface (bottom left) and implementation (bottom right)

PROTOTYPE 2 – X-Y TABLE WITH ONE LATERAL RAIL

The first prototype confirmed that two robotized cameras can provide useful points of view allowing a remote operator to follow what is going on during a trauma intervention. However, some viewpoints can be occluded by the local physician, as shown in Fig. 3.

The objective with the second prototype is to increase the range of motion of one of the cameras while not interfering with equipment in trauma rooms. This prototype was designed by a team of undergraduate Mechanical Engineering students. While the first prototype used two cameras mounted on two single axis side rails (Fig. 1), the second prototype depicted in Fig. 4 consists of one camera mounted on a two-axis rail system located directly above the stretcher to provide a wider range of

viewpoints, and a second camera mounted on a single axis lateral rail located at one end above the stretcher to provide the global view of the patient at different positions. The new prototype represents a significant improvement on the first prototype by adding a number of functionalities such as: i) enhanced detailed scene views using a single camera positioned over a two-dimensional extended area over the stretcher, ii) storage of the target location to allow semi-automated repositioning of the camera in case of view obstruction, and iii) enhanced interface using a tactile screen for the control of camera position, zoom and orientation.

A number of steps are still required in the development of this second prototype before it can be assessed in the anatomy room. The robustness of mechanical components has to be improved, covers have to be installed to minimize dust accumulation, and some esthetic improvements on the system are required. This is on-going work to be completed by June 2007.

CONCLUSION

The fundamental objective behind the robot-based tele-coaching system is to reconcile the modes of teleconference and medical examination of polytraumatized patients. It must allow to continuously visualize the general state of the patient while concentrating on the gestures posed by the on-site emergency specialist. With the two working prototypes, we plan to conduct a series of pre-clinical and clinical evaluations to assess the performance of the robot design, operator interfaces, transmission of video and audio streams, and the system's usability in trauma interventions, as a tool for training students and in continuing education program for emergency specialists. We also want to work at integrating automatic visual tracking and obstruction detection of the field of view of cameras [12], and a novel image coding algorithm for improved transmission rate and image quality. Audio and video transmission between hospitals in Québec will have to be done through the RTSS (*Réseau de télécommunication sociosanitaire du Québec*) network to ensure the security and integrity of data. The RTSS currently provides a bandwidth of 1.54 Mb/s for remote sites. Video and speech coding are therefore important issues to address.

By conducting such work, our objectives are to define the modalities for assistance of a remote trauma surgeon to an on-site emergency physician in the practice of trauma medicine, use tele-coaching as a means to measure the effectiveness of the CHUS tele-training program, as to the effectiveness of having

a virtual surgeon assisting the trauma team, compared to on-site trauma surgeon assistance right in the emergency room.

ACKNOWLEDGEMENTS

The authors gratefully acknowledge the contribution of Sono-Vidéo inc., the Faculty of Medicine and Health Sciences and the Faculty of Engineering of the Univ. Sherbrooke, in support of this work.

REFERENCES

- [1] Chan, B.T.B., *From Perceived Surplus to Perceived Shortage: What Happened to Canada's Physician Workforce in the 1990s?*, Canadian Institute for Health Information, June 2002, 67 pages.
- [2] Tachakra S., Level of diagnostic confidence, accuracy, and reasons for mistakes in teleradiology for minor injuries, *Telemedicine Journal & E-Health*, 8(1) :111-121, 2002.
- [3] Dunn B.E., Choi H., Almagro U.A., Recla D.L., Davis C.W., Telepathology networking in VISN-12 of the veterans health administration., *Telemedicine Journal and E-Health*, 6(3):349 – 354, 2000.
- [4] Kennedy C., Yellowlees P., The effectiveness of telepsychiatry measured using the Health of the Nation Outcome Scale and the Mental Health Inventory. *Journal of Telemedicine & Telecare*, 9(1):12 - 16, 2003.
- [5] Hicks L.L., Boles K.E., Hudson S.T., Madsen R.W., Kling B., Tracy J., Mitchell J.A., Webb W., Using telemedicine to avoid transfer to rural emergency department patients, *Journal of Rural Health*, 17(3): 220-228, 2001.
- [6] Bengler J., A review of minor injuries telemedicine, *Journal of Telemedicine & Telecare*, 5 Suppl 3 : S5-S13, 1999.
- [7] Tachakra S., Lynch M., Newson R., Stinson A., Sivakumar A., Hayes J., Bak J., A comparison to telemedicine with face-to-face consultations for trauma management., *Journal of Telemedicine & Telecare*, 6 Suppl 1: S178-S181, 2000.
- [8] Tachakra S., Jaye P., Bak J., Hayes J., Sivakumar A., Supervising trauma life support by telemedicine, *Journal of Telemedicine & Telecare*, 6 suppl 1 : S7-S11, 2000.
- [9] Wirthlin D.J., Buradagunta S., Edwards R.A., Brewster D.C., Cambria R.P., Gertler J.P., LaMuraglia G.M., Jordan D.E., Kvedar J.C., Abbott W.M., Telemedicine in vascular surgery: feasibility of digital imaging for remote management of wounds, *Journal of Vascular Surgery*, 27(6) : 1089-1100, 1998.
- [10] Rogers F.B., Ricci M., Caputo M., Shackford S., Sartorelli K., Callas P., Dewell J., Daye S., The use of telemedicine for real-time video consultation between trauma center and community hospital in a rural setting improves early trauma care : Preliminary results., *Journal of Trauma*, vol. 51 : 1037-1041, 2001.
- [11] Kaufmann C., Liu A., Trauma training: Virtual reality applications, *Technology and Informatics*, vol 81: Medicine meets virtual reality, IOS Press, 2001, pages 236-241.
- [12] Moisan, P., Analyse autonome d'activité de scènes vidéo numériques acquises par un système de télésupervision en traumatologie, Master's Thesis, Department of Electrical Engineering and Computer Engineering, Université de Sherbrooke, 2006.